



TECHNOTON

DECLARATION OF CONFORMITY

JV Technoton
and Digital Communications Technologies LLC
confirm that DUT-E 232 fuel level sensor
and Syrus SY2210 terminal



are compatible on the electrical and measuring characteristics

Accuracy error of combined measurement:
Fuel level – not more than 1%

Alexandr Kaplunski, Director



Ignacio Escallon, CEO

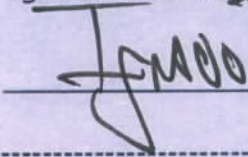

Based on test results report of 15.12.2015.
Recommended settings: see Annex



Recommendations on connection and set up of Syrus SY2210 terminal and DUT-E 232 fuel level sensor

1. DUT-E 232 fuel level sensor wiring connecting scheme:

- 1.1. White wire 232R (received data) of DUT-E should be connected to Rx input of RS232 port of SY2210 terminal;
- 1.2. Red wire 232T (transmitted data) of DUT-E should be connected to Tx input of RS232 port of SY2210 terminal;
- 1.3. Brown wire of DUT-E should be connected to GND wire of power source and to SG input of RS232 port of SY2210 terminal ;
- 1.4. Orange wire (power) of DUT-E should be connected to power source.

2. Wiring connecting scheme:

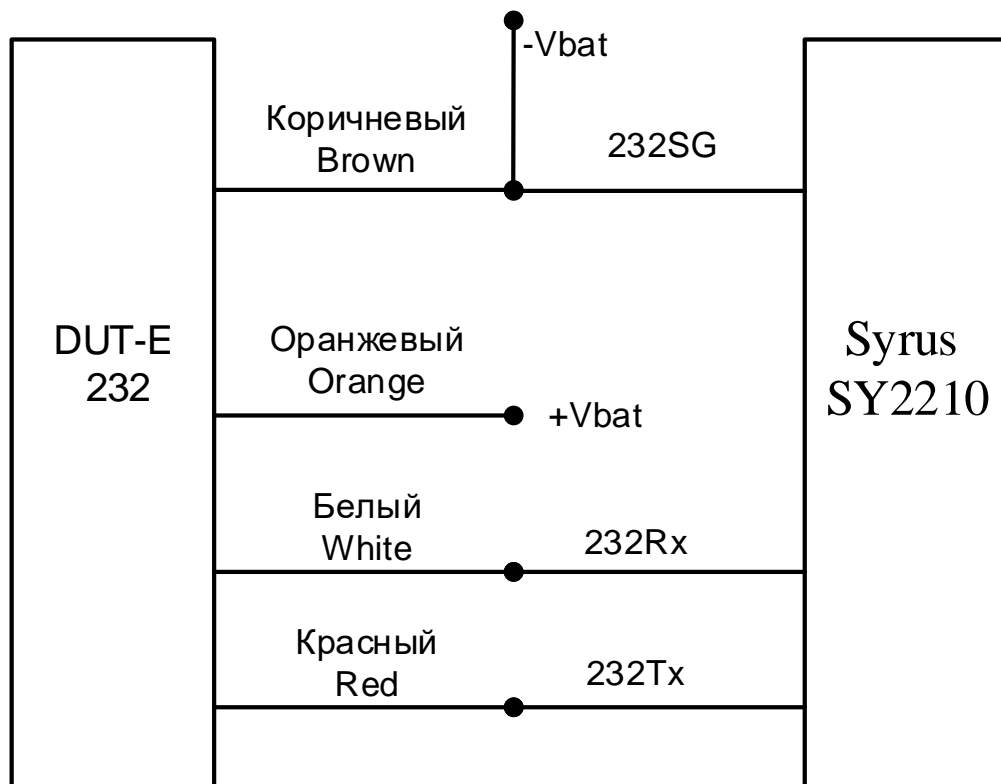

3. Configuration of DUT-E 232 fuel level sensor:

- 3.1. DUT-E 232 should be set with the help of service application Service DUT-E v 3.24
- 3.2. We should set automatic transmission mode ASCII with time interval - 60 seconds (Figure 1).



Рисунок 1

3.3. Output message Volume (Figure 2):

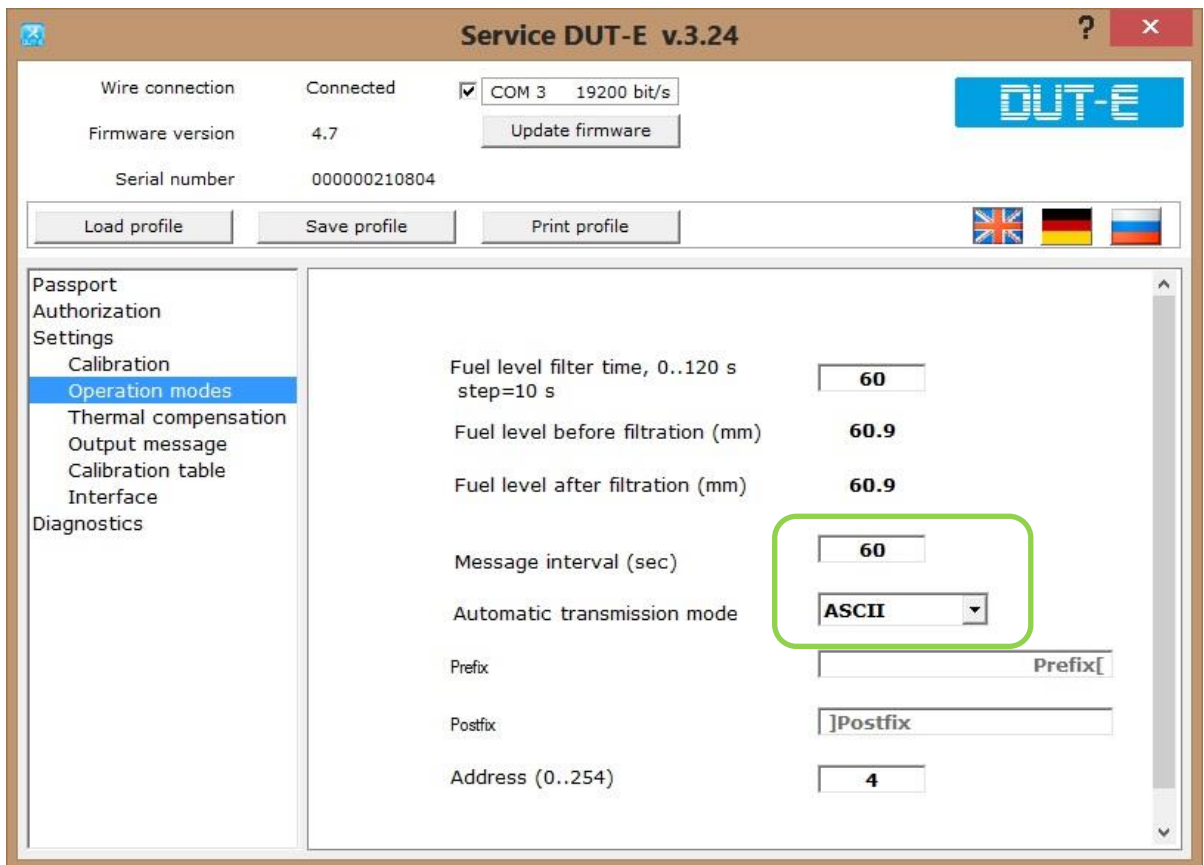
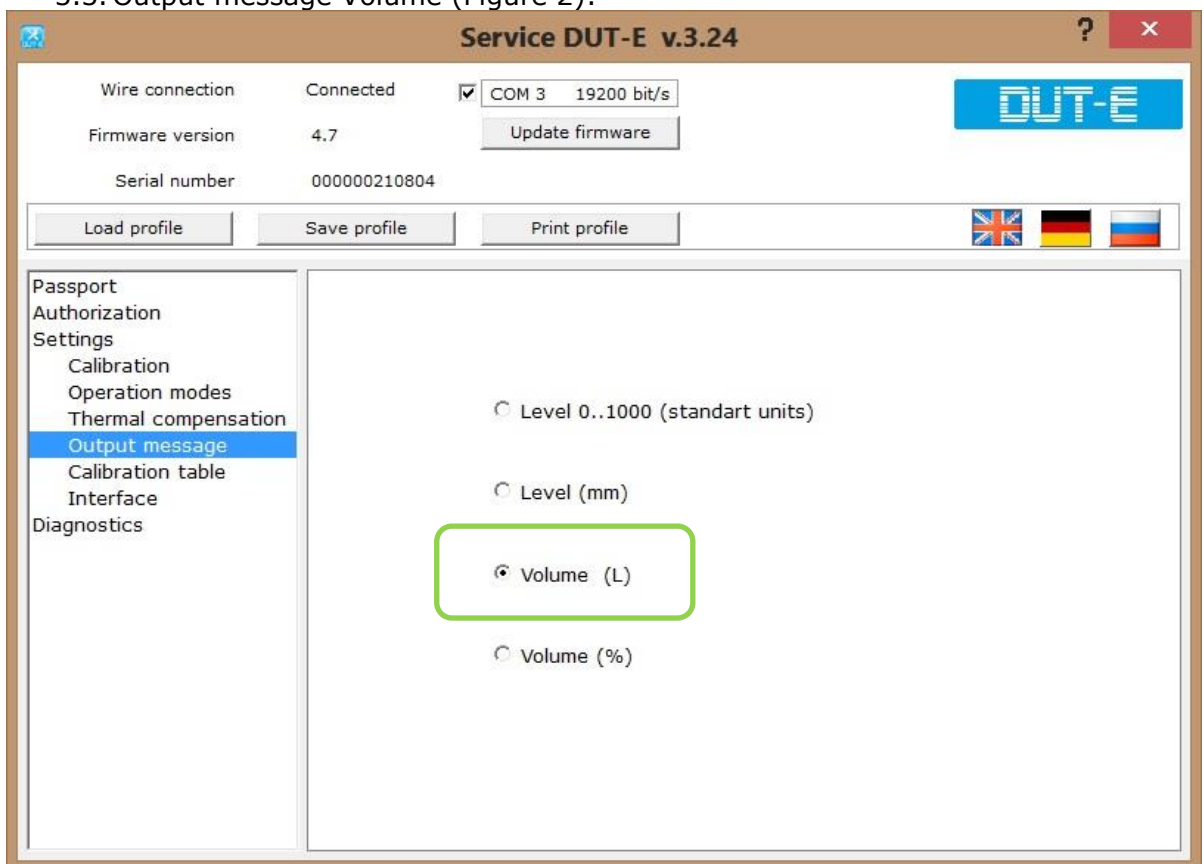

Figure 2

Fuel level sensor calibration table is performed according to DUT-E operation manual (Figure 3).

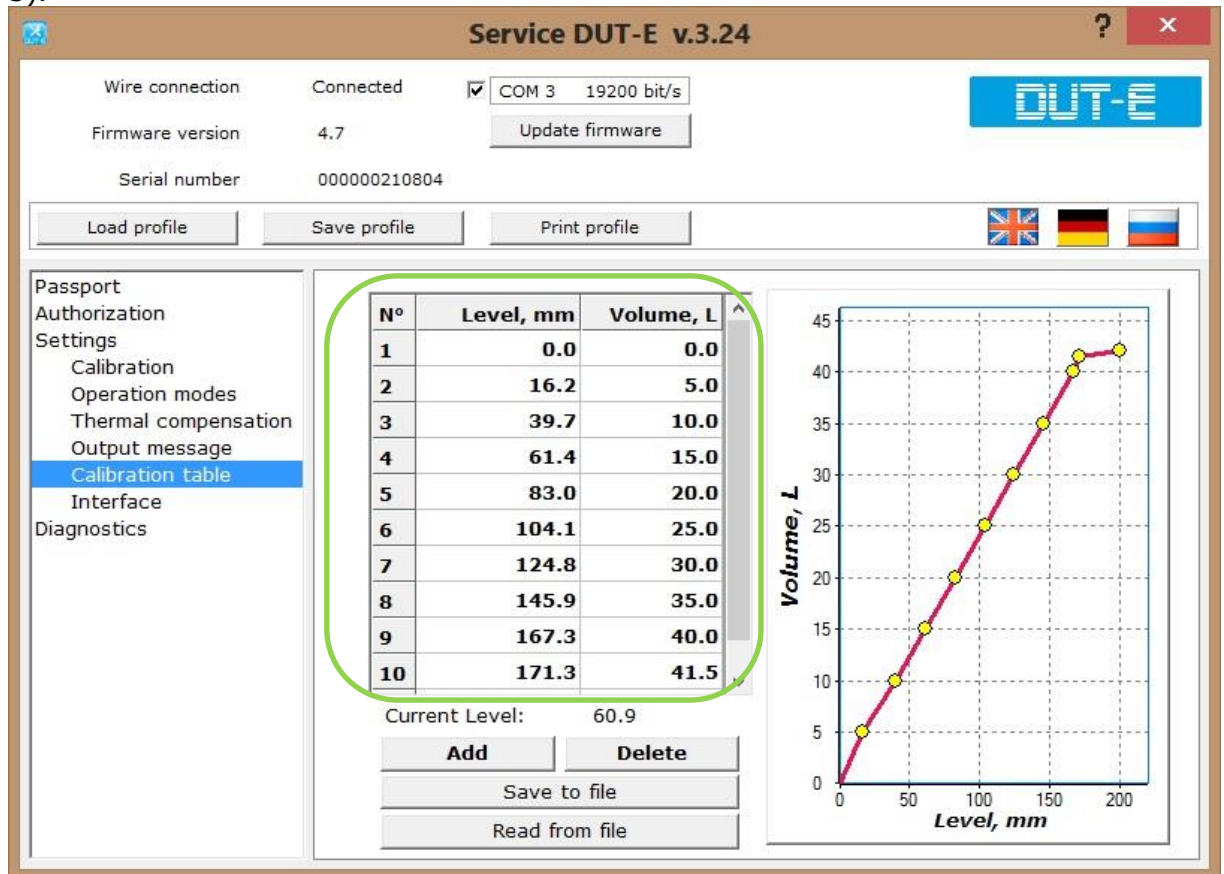

Figure 3

4. Configuration of DCT Syrus SY2210:

- 4.1. Insert SIM card into the terminal.
- 4.2. Configuring of the terminal and 3DTracking server were performed with the help of engineers of Digital Communications Technologies LLC

5. Operation performance check out:

Fuel level graph (Figure4).

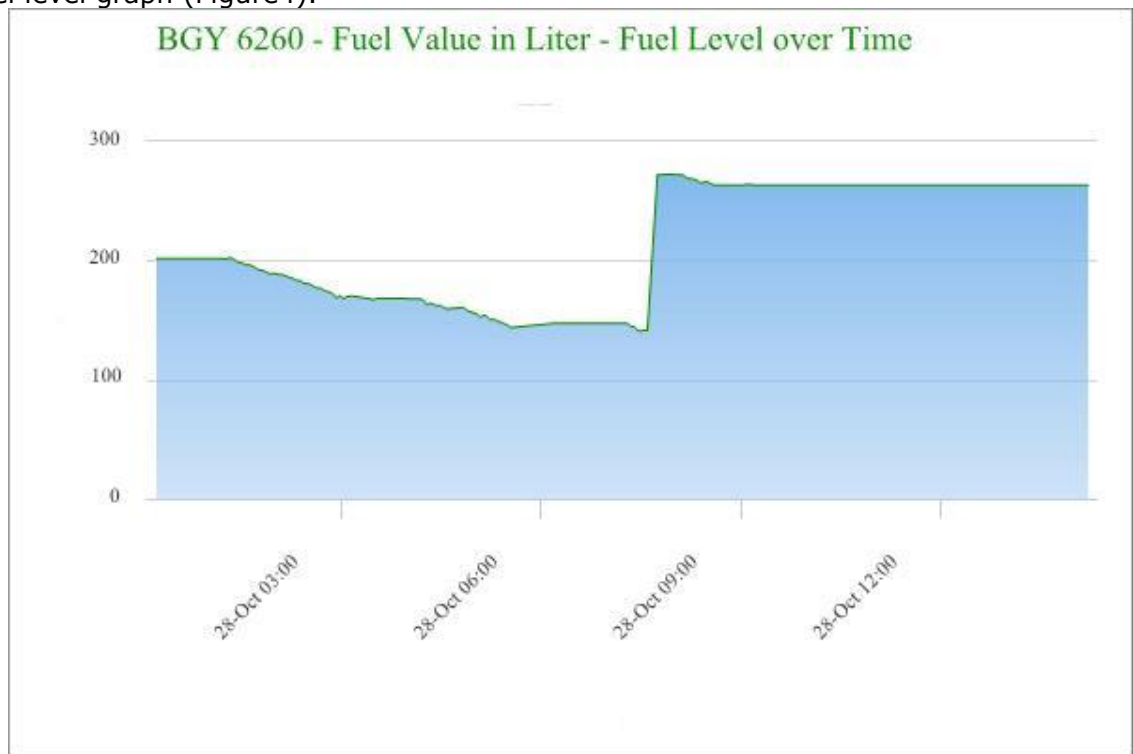

Figure 4

Configuration is completed.

Head of technical department

V.A. Panasuk